

Comparison of Biodiesel Fuel Prepared from Virgin Canola and Used Cooking Oil

Purpose: To compare the quality of biodiesel fuel prepared from virgin canola oil and used cooking oil using densitometry and chromatography.

Background: The two most common **biofuels** produced worldwide are corn-derived *ethanol* and *biodiesel*. In terms of its overall life cycle, biodiesel is considered approximately four times more energy efficient [1] *Ethanol* serves as a replacement for gasoline in traditional automobile engines, and *biodiesel* serves as a replacement for petroleum diesel fuel, in diesel (compression ignition) engines – such as those found in heavy-duty trucks, electrical generators, some cars and home heating boilers. The diesel engine was invented in 1897 by Rudolf Diesel, a German engineer, who claimed in 1911 that “[it] can be fed with vegetable oils and would help considerably in the development of agriculture of the countries which use it.” [2]

The diesel engine won Grand Prizes at the Paris Exhibition in 1900 and the Brussels World’s Fair in 1910 *while running on peanut oil!* But unfortunately, research on renewable fuels slowed shortly thereafter due to the rise of petroleum oil companies, and mysterious drowning death of Rudolf Diesel during a steamboat ride in the English Channel... By 1936, however, Mack began producing and selling diesel-powered trucks in the United States, and Daimler-Benz (the ancestor of Mercedes-Benz) started large-scale production of passenger cars in Germany. From mid-century until nowadays, diesel engines have become commonplace in factories, power plants, boats, school busses, railway locomotives, construction vehicles and equipment. The following experiment will demonstrate how both virgin (unused) cooking oil and recycled cooking oil can be converted to high quality biodiesel fuel.

The quality of all fuels is determined by a number of parameters defined by an organization known as ASTM International. The ASTM D6751 is the standard specific to biodiesel fuel and is used to test combustion properties, cold-flow properties and concentration of residual fatty acids, alcohols and catalysts. [3] You will use analytical methods known as densitometry and thin layer chromatography to roughly compare the quality of your home-brewed biodiesel. The ASTM tests are much more rigorous, and require specialized instrumentation such as a gas-chromatography mass spectrometer (GC-MS) that your instructors will show you.

One essential math skill for chemistry is the ability to perform **dimensional analysis** – i.e. cancel out the proper units so you can measure your chemical reagents and catalysts accurately. In chemistry, the **mole** is used as a standard unit to describe the number of molecules in a measured mass of a substance. There are 6×10^{23} molecules in a mole (therefore a mole is like a very big “dozen”). Masses of substances are typically measured in grams, and a substance’s **molar mass** is given in units of *grams per mole* (g/mol). Since all atoms have a known molar mass (that can be found on a periodic table), you can easily calculate the molar mass of any substance if you know its *molecular structure* or *molecular formula*. For example, the substance known as *water* has a molar mass of 18.0 g/mol.

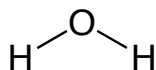
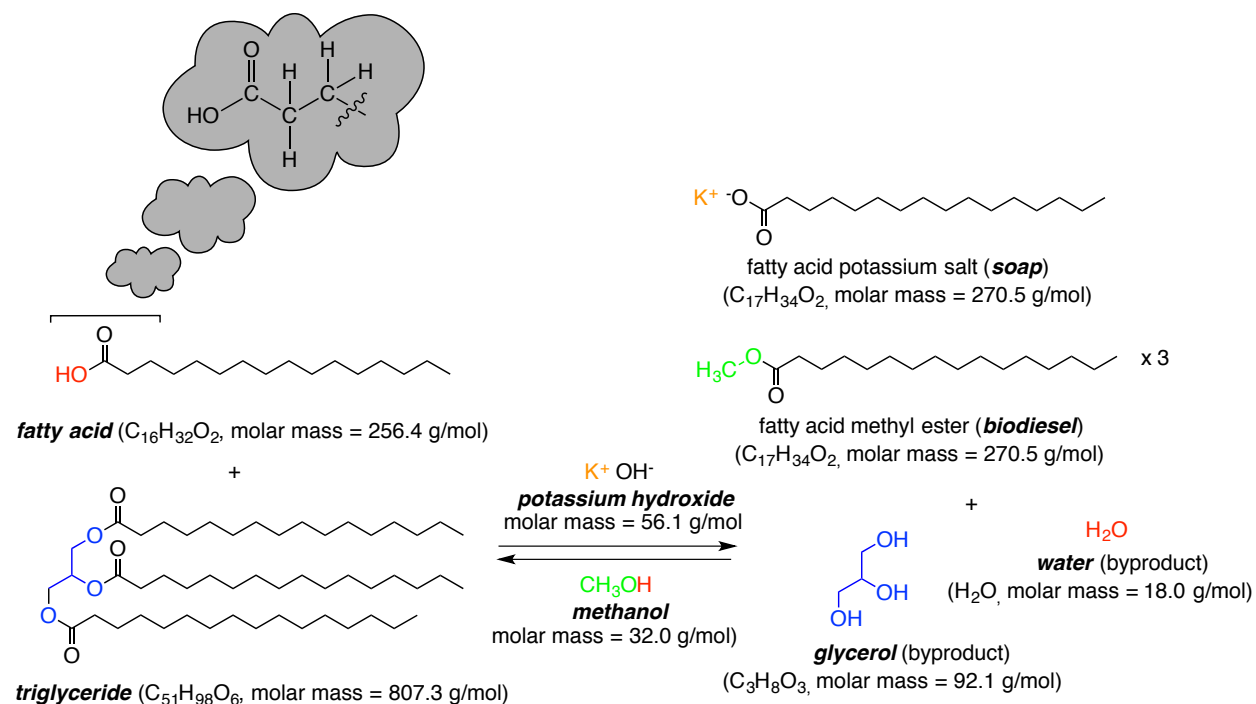

Figure 1: Molecular structure of water (molecular formula = H₂O)

Skills Problem 1: Use dimensional analysis to determine how many moles of water are present in 1.00 US quart of water (1 US gallon = 4 US quarts = 3.78L; density of water = 1.0 g/1.0 mL; molar mass of water = 18.0 g/mol):

Basic Biodiesel Chemistry: Biodiesel fuel is more accurately described as a mixture of *methyl esters*. The specific identification of substances comprising the mixture is beyond the scope of this experiment, but it is important to understand that, chemically speaking, biodiesel fuel is not the same cooking oil. It is a commonly thought that someone can simply filter and pour used cooking oil into a diesel engine and run a car, for example. While this is possible with some modifications to the fuel lines and engine, it is not advisable because of the *fatty acids* present in used cooking oil, which – like all acids – can erode metal and eventually ruin the engine. Fatty acids result from a *hydrolysis reaction* between water and cooking oil at high temperatures (such as those found in a fry-o-lator). To properly prepare biodiesel, fatty acids must be *neutralized* with base (we will use potassium hydroxide, a.k.a KOH) and removed from the biodiesel reaction mixture. The biodiesel reaction is called a *transesterification reaction* because it converts one type of *ester* (a *triglyceride*) to another (a *methyl ester*). Below is a schematic showing the transesterification reaction used to make biodiesel:



Scheme 1: Transesterification of used cooking oil components (fatty acids and triglycerides) to make biodiesel, soap and byproducts (glycerol and water)

Materials: You will need the following chemicals and materials to make biodiesel. Pay special attention to handling of chemicals and glassware. Glassware becomes extremely slippery when covered in oil and therefore plastic ware is used whenever possible.

Chemicals	Chemical Safety	Glassware	Other
Virgin/Used Canola Oil	Slippery, do not spill	Burette 300 mL beaker	Safety goggles!!! Tweezers, scissors
Methanol	Use in fume hood. Do not inhale vapors. Flammable	100 mL graduated cylinder	Aluminum foil or watchglass Funnels, thermometers
Potassium Hydroxide (KOH)	Avoid contact with skin/eyes	300 mL separatory funnel	Magnetic stir bar, stir plate and stir bar remover
Hexanes : DCM (1:1)	Use in fume hood. Do not inhale vapors.	TLC chamber	10 mL volumetric flask
Silica Gel TLC Plates	Use caution when handling.	Watch glasses	Test tubes
KMnO ₄ TLC stain	Oxidizer. Avoid contact	GC vials Mason jar	Stopwatch Calculators/Rulers

Table 1: List of chemicals and lab equipment needed for this experiment.

DAY 1

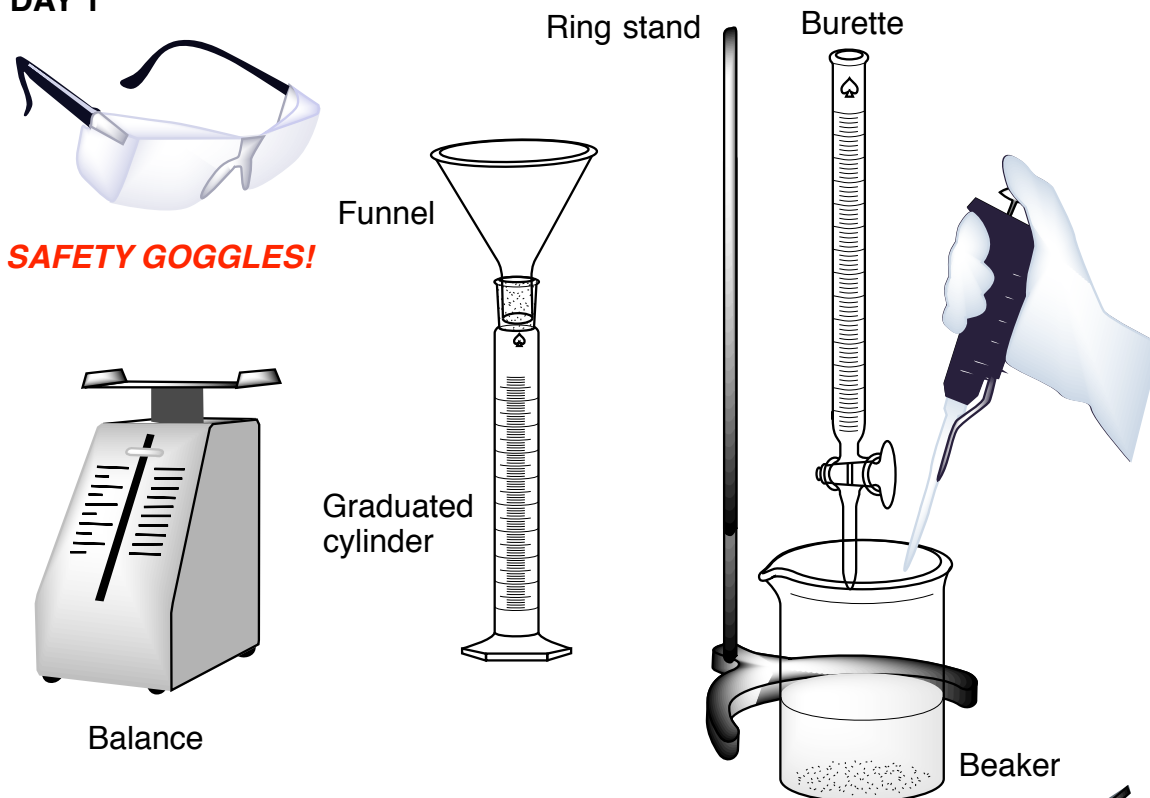

DAY 2-3

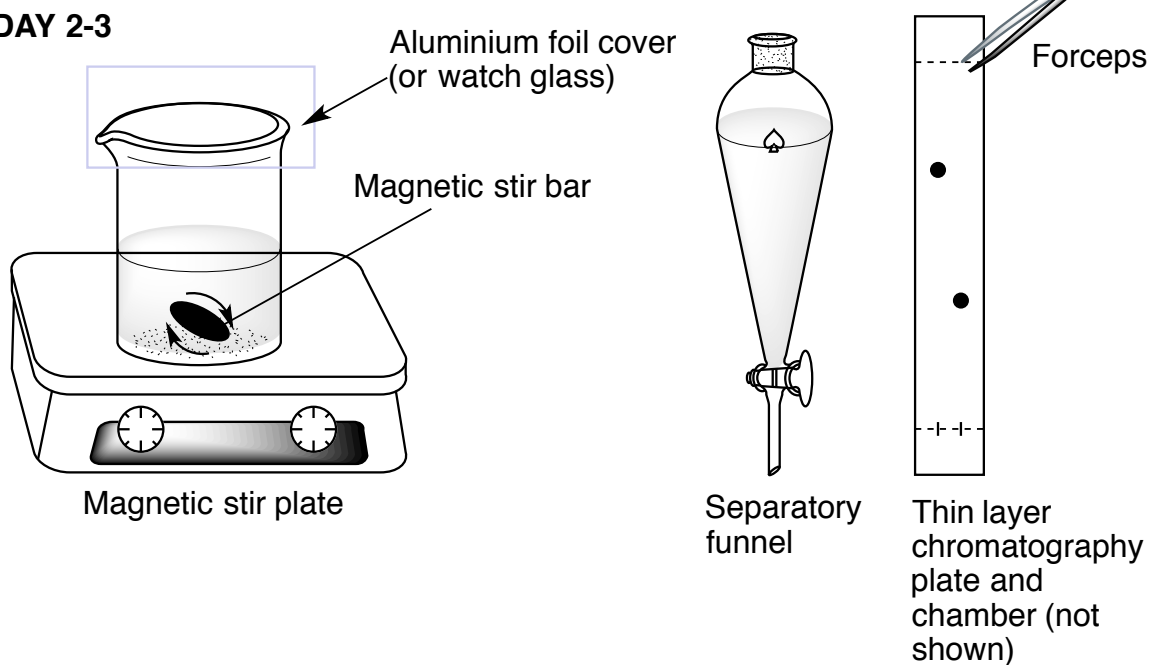
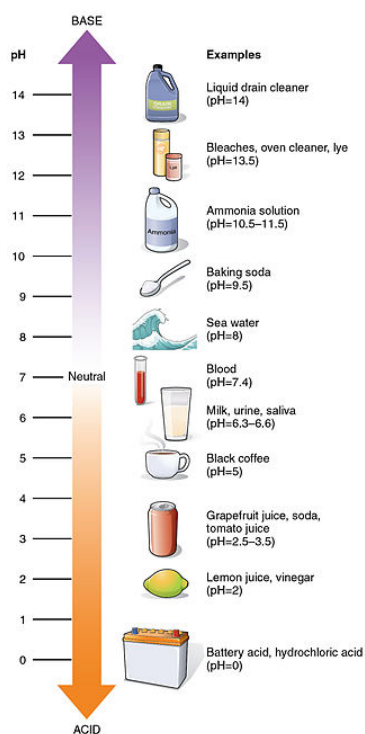

Figure 2: Basic laboratory equipment used to make biodiesel.

Procedure Day 1: Today you will perform a titration on your cooking oil to determine the amount of “free fatty acid” (FFA) present. This is an important measurement used for biodiesel production at any scale. For example, a person making biodiesel for personal use in their car uses the identical procedure as a company making thousands of gallons of biodiesel per day! Therefore, it is a very important procedure and must be performed accurately. It is important to answer Skills Problems 2 and 3 correctly before beginning the titration.

1. Select a 2’x2’ bench space and cover it in paper spill towels.
2. Obtain 250 mL of *either* virgin or used cooking oil from your instructor.
3. Perform a **titration** on your oil to determine its FFA content. A titration is a reaction between an acid (in this case your fatty acids) and a base (in this case KOH) used to determine the point at which the **pH** of solution is neutral. pH is short for “parts hydrogen” and is used to describe the acidity or basicity of an aqueous solution. Some examples of substances of different pH are below. Substances with pH from 0-7 are “acids” and those with pH from 8-14 are “bases”. Fatty acids and KOH have pHs of approximately 2-3 and 11-12, respectively, when dissolved in water.



3a. Add 20 mL of 0.1% (weight/weight or “w/w”) KOH solution to a burette held in place by a ring stand. The 0.1% (w/w) KOH solution is prepared by your instructor by adding 1.0 g of KOH into 1000 mL of water.

3b. Using a pipette, add 1.0 mL of your cooking oil (either virgin or used) to a **tared** Dixie cup. Add 10 mL of isopropyl alcohol (or another appropriate alcohol – butanol, propanol or ethanol) to the beaker and mix thoroughly. Record the mass of the cooking oil: _____ g

3c. Add 2-3 drops of phenolphthalein solution to the beaker containing oil and alcohol prepared in step 3b.

4d. Add the 0.1% KOH solution to the beaker from step 3c slowly, dropwise while swirling the beaker. Record the amount of solution required for the solution to change to (and remain) pink.

Volume of 0.1% KOH solution used: _____ mL

Figure 3: pH scale with household examples.

Skill Problem 2: Calculate the number of moles of KOH in 1000 mL of a 0.1% w/w solution of KOH.

Skill Problem 3: Based on the volume you measured in your burette in step 3d, how many moles of KOH were required to titrate (i.e. neutralize) 1.0 mL of your oil?

Skill Problem 4 (Homework): Based on Skill Problem 3 and the fact that you are starting with 250 mL of cooking oil in your biodiesel reaction, how many grams of KOH is needed to neutralize the fatty acids present in your biodiesel reaction?

Procedure Day 2: Today you will make biodiesel using the basic equipment seen on the bottom half of Figure 2. You will also use the information on FFA content obtained from your titration. The general rule of thumb is to use 0.1 and 6.0 molar equivalents of KOH catalyst and methanol, respectively, to make biodiesel. Let's apply this to what you know about dimensional analysis and **reaction stoichiometry** (moles) in an **equilibrium reaction**.

You can see from the bi-directional arrows in Scheme 1 that the transesterification reaction proceeds in two directions 1) towards the products (i.e. methyl ester, soap, glycerol, water) and 2) back to the reactants (triglycerides and fatty acids). One way to "push" the reaction to completion is to use an excess of one of the reagents. Because it is the least expensive, methanol (CH_3OH) is used as the excess reagent. We call this excess "molar equivalent excess" because we are comparing moles of methanol to moles of starting triglyceride. Complete Table 2 below before starting the procedure. *How many molar equivalents of biodiesel formed from 1 molar equivalent of triglyceride (Scheme 1)?*

Compound	Volume (mL)	Density (g/mL)	Mass (g)	Molar Mass (g/mol)	Moles	Molar Equivalents
triglyceride	250	0.95				1.0
methanol		0.79				6.0
potassium hydroxide	N/A	N/A				0.1
biodiesel (methyl ester)		0.87				

Table 2: Stoichiometry Requirements for Biodiesel Synthesis

Note that the KOH is a *catalyst* in the reaction. This means that very little KOH is needed (0.1 mol eq), and it is theoretically recycled in the course of the reaction. However, since some of the potassium ions (K^+) are used to "trap" FFAs as soap, some of the catalyst is consumed in the reaction. Add the mass of

KOH you calculated for Skill Problem 4 to the mass of KOH you calculated in Table 2 to obtain the amount of catalyst needed for your reaction. _____ g KOH needed for reaction.

1. Weight this amount of catalyst on wax paper, and immediately transfer it to a clean beaker. The catalyst is *hygroscopic*, meaning it will absorb water quickly, and appear to be melting, but it is not. It is now a very concentrated aqueous solution of KOH.
2. To the beaker containing KOH, add the volume of methanol that you calculated in Table 2. Stir with a magnetic stir bar on a magnetic stir plate (Figure 2) to ensure that all catalyst dissolves in methanol. Cover with aluminum foil or a watch glass to ensure no methanol evaporates. Perform in a fume hood.
3. Slowly, while stirring, add your cooking oil to the methanol/KOH solution and allow the reaction to stir. Secure the cover on the beaker to ensure that no methanol evaporates and allow reaction to stir **gently** for several hours. Vigorous stirring is OK while you are watching the reaction, but allowing reaction to stir vigorously without supervision is not recommended because the stir bar might misbehave and stop stirring altogether.
4. After 1-2 hours pour your reaction into a separatory funnel and allow to settle overnight. Make sure the stopcock is closed!

Skills Problem 5 (Homework): Glycerol is a by-product of biodiesel production and has a variety of uses in the pharmaceutical, cosmetic and commodity chemical industries (sunscreen, toothpaste, shampoo, chewable vitamins, fuel additives, etc. all contain glycerol). Based on the chemical structures seen in Scheme 1, how many molar equivalents do you expect from your reaction? What is the volume of glycerol you can expect to produce (density = 1.13 g/mL)? How much glycerol is made per year at a biodiesel plant that processes 10,000 gallons of used cooking oil per day?

Procedure Day 3: Today we will perform *analysis* of our products. The analysis is a simple version of some of the tests performed during ASTM certification of biodiesel (so it can be taxed, and sold legally). Firstly, you will notice that your reaction mixture has separated into two distinct *phases*. The top phase contains biodiesel (methyl esters) and the bottom phase contains, glycerol, residual excess methanol and catalyst. Like salad dressing (oil and vinegar) these two phases separate due to differences in both polarity and density. We will measure the density of your biodiesel and compare it to the known density of cooking oil. We will also perform thin layer chromatography (TLC) on your biodiesel and compare to TLC of the triglyceride starting material and a known standard biodiesel methyl ester sample (methyl oleate).

Figure 4. Phase separation of reaction mixture.

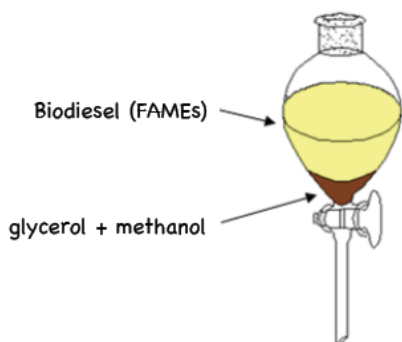

Thin Layer Chromatography (TLC) Theory and Applications: TLC is a method used routinely by organic chemists to monitor the progress of a reaction or assess the quality of a product during workup and purification. TLC plates are typically made of a silica-based *stationary phase* stuck to an aluminum or glass backing. The separation of individual molecules is dependent on the chemistry of the stationary phase as well as that of the solvent (*mobile phase*). In this lab, the non-polar solvents hexanes and dichloromethane are used with silica TLC plates to

achieve the separation of biodiesel from triglycerides. You will use forceps to manipulate your “spotted” TLC plate between a TLC chamber containing the mobile phase and a potassium permanganate (KMnO_4) staining reagent.

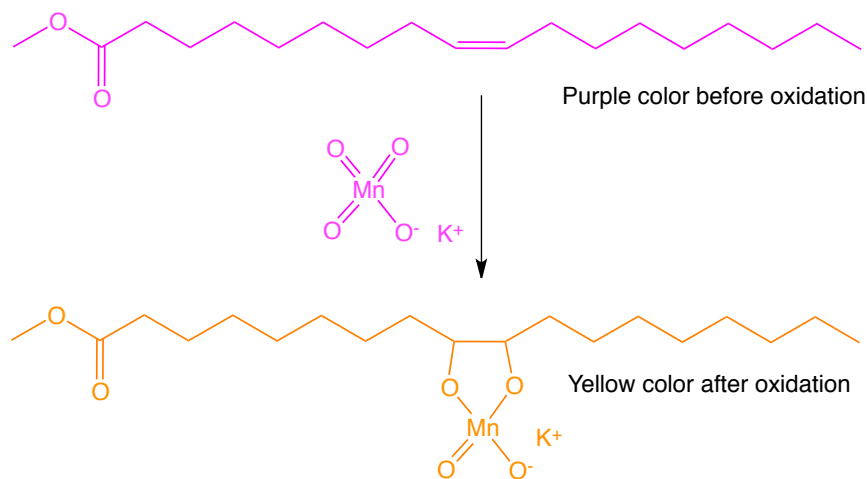

Scheme 2: KMnO_4 stain of methyl oleate during TLC plate development. The reaction is rapid and does not require heating.

A variety of TLC stains are available for visualizing specific molecules' functional groups. [4] Your experiment requires visualization of triglycerides and biodiesel methyl esters that each containing carbon-carbon double bonds (not shown in Scheme 1). KMnO_4 is a strong oxidant capable of oxidizing carbon-carbon double (and triple bonds). As such, a complex is formed (Scheme 2) that gives bright yellow "spots" on the TLC plate indicating the presence of triglycerides and biodiesel methyl esters. The remainder of the plate turns a deep purple color without heating.

1. In a small test tube, add 1-2 drops of your biodiesel product (top layer of separatory funnel) and 1-2 mL of dichloromethane or hexane and stir.
2. Obtain standard samples of biodiesel methyl ester and triglyceride cooking oil from your instructor. Perform TLC with standard samples and your product by spotting in 3 *lanes* on the TLC plate. Using forceps, drop the TLC plate in chamber containing 1:1 hexane : DCM mobile phase and allow solvent front to run *almost* to the top of the plate. Remove the TLC plate and dip in KMnO_4 solution for 1-2 seconds – keep a hold of it with the forceps! Dab the plate on a napkin and record the results in Table 3 below. R_f is the ratio of the distance the spot travels and the distance the solvent front travels (see 3 below).

Compound	Role in reaction	R_f of KMnO_4 spot(s) % Completion of reaction
Triglyceride standard sample	Reagent	$R_f =$
Biodiesel methyl ester standard sample	Product	$R_f =$
Your biodiesel methyl ester sample	Product	$R_f =$

Table 3: TLC results from biodiesel synthesis

3. Draw the spots from your TLC plate (after it has run) on the "after" plate below. Indicate which spot(s) are starting material (triglyceride) and product (biodiesel methyl ester).

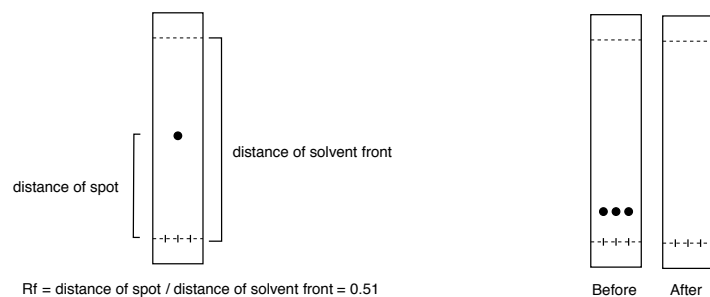

4. Measure the density of your biodiesel. Compare to the density of the triglyceride that you measured on Day 1, step 3b and the density of the biodiesel methyl ester recorded in Table 2.

Density of triglyceride measured on Day 1 (3b): _____ g/mL

Known density of biodiesel: _____ g/mL

Density of your biodiesel: _____ g/mL

Volume of your glycerol : methanol mixture: _____ mL

Density of your glycerol : methanol mixture: _____ g/mL

Is there any error in your measurement of biodiesel density? What are some possible sources?

Using Table 2 in Reference 5, determine the density of a 40: 60 glycerol: methanol mixture at 25°C. You will have to plot data and extrapolate a line using point slope form.

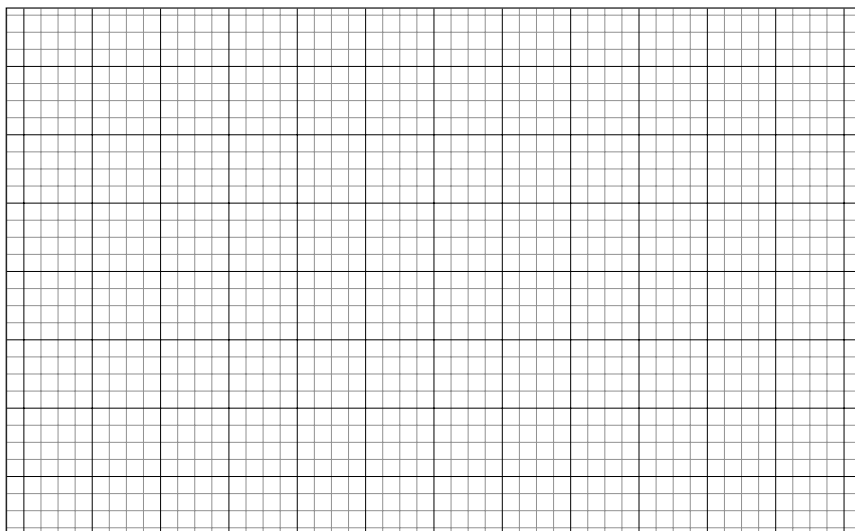

Conclusions:

1. Based on the density and TLC measurements of your group and the other students in class, are there any differences in the quality of the biodiesel made from virgin vs. used cooking oil?
2. Based on your results and understanding of biofuels, what are the economic and environmental benefits of making biodiesel from used cooking oil?

References:

1. Hill, J., Nelson, E., Tilman, D., Polasky S., Tiffany D. 2006. *Environmental, economic and energetic costs and benefits of biodiesel and ethanol fuels*. Proc. Nat. Acad. Sci. USA 103, 30, 11206-11210.
2. Pahl, G. Biodiesel: Growing a New Energy Economy. 2nd Edition. Chelsea Green. 2004.
3. <https://www.astm.org/Standards/D6751.html>
4. http://www.chemistry.mcmaster.ca/adronov/resources/Stains_for_Developing_TLC_Plates.pdf
5. Ghotli et. al., *Selected physical properties of binary mixtures of crude glycerol and methanol at various temperatures*. J. Ind. Eng. Chem. (2014): <http://dx.doi.org/10.1016/j.jiec.2014.05.013>

5 Simple Steps to Safe Waste Clean Up:

All of the materials used in this lab are safe for disposal in the sink ☺

- 1 - Potassium Hydroxide solution (such as the 0.1% w/w solution used for your titration) is sold as “Drain-O” and used to remove fats and oils from sink pipes so it is absolutely OK to pour in the sink. The reaction produces soaps, exactly as you made from your FFAs, which easily flow down the drain.
- 2 - Methanol is used for wastewater treatment and also OK to pour in the sink in small amounts.
- 3 – Isopropanol is rubbing alcohol and can also go down the sink in small amounts.
- 3 - Glycerol is a benign chemical (it’s used in shampoo and toothpaste) and can also go down the sink - just like taking a shower or brushing your teeth.
- 4 - You will keep your home-brewed biodiesel in a jar (to take home). It is also 100% biodegradable in case you ever wish to discard, it is also OK to pour in the sink. You can also use it for heating fuel in a lantern or a boiler.